

TECHNOTORC HYDRAULIC FLANGE SPREADER (TFS-14)

Features :

- Integrated wedge concept: Friction-free, smooth and parallel wedge movement eliminates flange damage and spreading arm failure
- Unique interlocking wedge design - no first step bending and risk of slipping out of joint
- Requires very small access gap of only 6 mm
- Stepped spreading arm design - each step can spread under full load
- Few moving parts mean durability and low maintenance

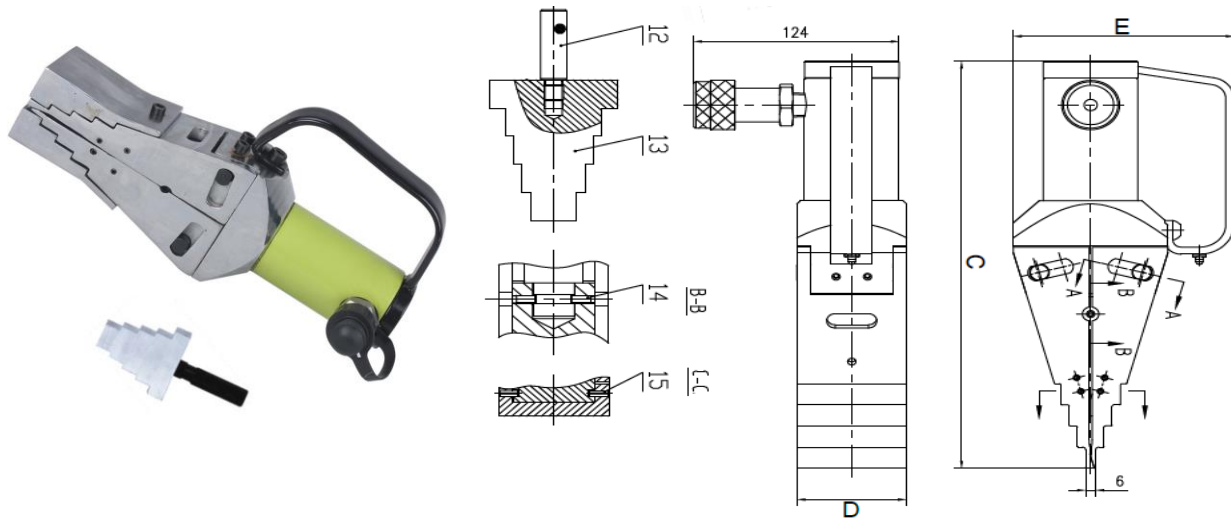

TECHNICAL SPECIFICATION

Model Number	Maximum Operating Pressure (psi)	Maximum Spread (in)	Power Source	Spreading Force (imperial tons)	Maximum Spreading Force (ton)	Maximum Spreading Force (kN)	Capacity (imperial tons)	Weight (lbs)
TFS-14	10,000	3.16	Hydraulic	14	14	125	14	36.3